



STANDARD

PROFESSIONAL

INSTALLATION

GUIDELINES

The Basic DIRECTV residential installation includes the following:

1. As a minimum, each customer must receive two (2) pre-calls from the Installation Company prior to any work being performed. Contact the customer:
 - Two (2) to three (3) days in advance of their scheduled installation to confirm both the appointment window and work to be performed
 - Installer or dispatcher will phone the customer on the day of the scheduled appointment to confirm when they will arrive to begin the job. In the event that the agreed upon timeframe is in jeopardy, the customer must be contacted and notified of any changes.
 - It is recommended, but not required to contact the customer within two (2) weeks post installation to confirm customer satisfaction
2. Arrival at customer's residence within the designated window of time.
3. Completion of a site survey and planning the installation with the customer (Cable routing, antenna location, connection of devices). Refer to the DIRECTV Installation Manual - pages 3-1 to 3-3.
4. Verify services ordered and work to be performed with customer. Any non-standard/custom work with incremental costs associated must be communicated and agreed to in writing prior to commencement of installation.
5. Routing and properly attaching approved RG-6 cable through external and internal walls as needed. Routing of cable through attics and/or crawlspaces is considered standard. Refer to the DIRECTV Installation Manual - pages 4-3, 6-1 to 6-2.
6. Use of DIRECTV approved drop materials is required.
7. Grounding to meet Local / NEC requirements. Refer to the DIRECTV Installation Manual - pages 5-1 to 5-4.
8. Properly mounting to customer's home, aligning and peaking satellite antenna for maximum signal strength. Standard mounting includes, but is not limited to the roof, eave, outside wall, balcony, deck and chimney. Refer to the DIRECTV Installation Manual - pages 4-1 to 4-3, 10-1 to 10-3.
9. In any market where local channels are delivered from the 110 or 119 orbital slots or on HD installs or upgrades, a Triple Sat ODU is required on all installations.
10. Dual cable run is recommended from the ODU to the ground block on all installs.
11. Dual cable must be run to all DIRECTV DVR'S.
12. Installation of one or more DIRECTV System IRDs as indicated on the customer's work order.
13. All IRDs must be connected to a land based telephone line. Refer to the DIRECTV Installation Manual - pages 7-1 to 7-2.

14. Connection of existing off-air antenna or active cable drop (enabling TV to function as it had prior to DIRECTV installation).
15. Connection of existing co-located devices (VCR, functioning surround sound, DVD, video games, etc.) and programming the DIRECTV Universal Remote Control to operate all applicable devices.
16. Completion of a system test verifying signal strength, access card match and telephone connectivity. Refer to the DIRECTV Installation manual Page 13-1
17. Activation of DIRECTV service with the customer on the phone.
18. Cleaning up any mess made during installation and removing debris from the customer's residence. This includes removal of empty equipment boxes at customer's request.
19. Customer education on system operation and features (min. 20 minutes). Refer to the DIRECTV Installation Manual - pages 11-1 to 11-2.
20. Completion of all applicable forms and obtaining customer's signature certifying the job was completed to their satisfaction.
21. Leaving installation company name and toll free telephone number if applicable with the customer enabling them to contact the Installation Company directly if there are any problems with the installation.
22. If, after arriving at a job the installation cannot be completed and is cancelled, the installer must explain to the customer in detail why they were not able to complete the job.

DIRECTV RECOMMENDED RATES FOR REQUESTED SERVICES BEYOND WHAT IS PROVIDED IN A STANDARD PROFESSIONAL INSTALLATION

The following list contains DIRECTV's recommended rates for additional services applicable nation-wide. These rates were established after reviewing all current HSP charges for such services, taking into account retail rates so that these rates are reasonably competitive. These rates shall be distributed to all DIRECTV Entertainment Consultants nationally in order to help educate DIRECTV customers as to what the approximate rates should be for certain services not included in a standard professional installation.

ADDITIONAL CHARGES TO BE PAID TO THE INSTALLATION COMPANY UPON COMPLETION OF INSTALLATION:

	<u>Not to Exceed</u>
WALL FISH	\$60.00 per
POLE MOUNT REMOVAL DIG	\$65.00
POLE MOUNT REMOVAL CUT	\$20.00
POLE MOUNT/ PER CUSTOMERS REQUEST	\$75.00
SIDEWALK BORE	\$35.00
MIRROR OUTLET	\$45.00
ADDITIONAL OUTLETS WITHOUT RECEIVERS	\$45.00
ADDITIONAL OUTLETS WITH RECEIVERS	\$45.00
SEPARATE TRIP ADDITIONAL OUTLETS	\$85.00
NON -PENETRATING/ SLED MOUNT	\$65.00
BALCONY MOUNT/BRACKETS	\$30.00
FLAT CABLE JUMPER	\$5.00
BURY CABLE/ OUTLET	\$30.00
LINE AMPS	\$15.00
DIPLEXERS (2)	\$15.00
WIRELESS PHONE JACK	\$75.00
RELOCATE DISH (CUSTOMER REQUEST)	\$97.50



Installation & Customer Service Manual

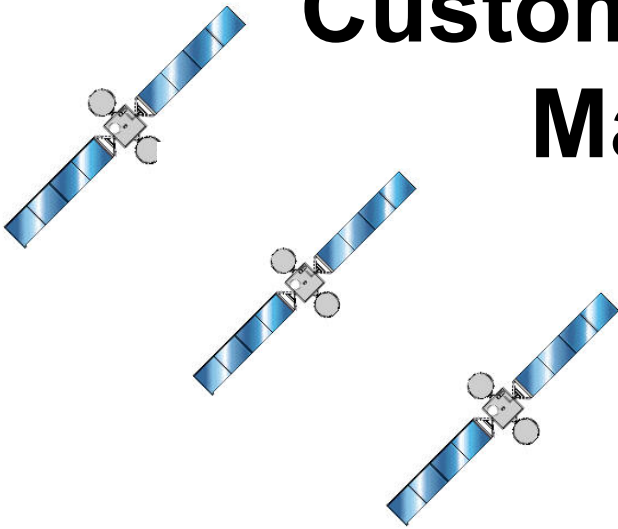

Table of Contents

1	BASIC SATELLITE THEORY AND BACKGROUND	9
1.1	Key Elements	9
1.2	Programming / Carrier	9
1.3	Uplink	9
1.4	Receiving Equipment	10
1.5	Satellite Link Analysis	10
1.6	Creation of the DIRECTV System	10
1.7	DIRECTV Receiver Control Policy.....	11
2	INTRODUCTION	12
2.1	Pre-Call	12
2.2	Identification.....	12
2.3	Verification	12
2.4	Pre-Installation Process	13
3	SITE SURVEY	13
3.1	Preliminary Evaluation	13
3.2	Unobstructed Line of Sight	14
3.3	Ground Source.....	14
3.4	Access to Phone	14
3.5	Distribution Location	14
3.6	TV Set Location	14
3.7	Customer Concerns.....	14
3.8	Walk the Customer through the Installation in Detail.....	14
3.9	Installation Overview - Standard Installation	16
3.10	Non-Standard Installation	17
3.11	Safety Considerations.....	17
3.12	Working On Roof or Wall Mounts	17
3.13	Ground Mounts	18
3.14	Know Your Limitations!	18
4	ODU INSTALLATION	18
4.1	Antenna Assembly	18
4.2	Wall Mounting – Wood.....	18
4.3	Brick Mount.....	19
4.4	Roof Mount Assembly.....	20
4.5	Positioning	20
4.6	Pole Mount - Hole Size and Location	20
4.7	Concrete	20
4.8	Trench / Drop Bury.....	20
4.9	Cable Run	21
4.10	ODU Assembly	21
5	GROUNDING & BONDING	21
5.1	Ground Block	22
5.2	Suitable Ground Sources.....	22
5.3	#4 or #6 Ground Wire to Electrode.....	22
5.4	Electrical Ground Rod.....	22
5.5	Panel Box Lug or Meter Base.....	23
5.6	Metallic Service Raceway.....	23
5.7	Grounded Metal Structure (Mobile Home).....	23
5.8	Sprinkler System – Commercial Buildings.....	23
5.9	Supplemental Electrode Bonding Ground Rod.....	24

5.10	Summary of Grounding.....	25
6	CABLE ROUTING	25
6.1	Conventional Foundation.....	25
6.2	Slab Foundation.....	26
6.3	Cable Considerations	26
7	TELEPHONE LINE INSTALLATION AND TROUBLE-SHOOTING.....	27
7.1	Installation.....	27
7.2	Trouble-shooting Phone Lines.....	28
7.3	Valid Reasons for Non-Impulse IRDs	28
8	ACCESS CARDS	28
9	INTEGRATION WITH THE CUSTOMER'S EQUIPMENT	29
9.1	Tuning VCRs.....	29
9.2	Stereo / Surround Sound	29
9.3	Picture-in-Picture (PIP).....	30
9.4	(HDTV) High Definition TV.....	30
10	ODU ALIGNMENT AND PEAKING	32
10.1	General	32
10.2	Signal Strength Meter – Alignment.....	32
10.3	IRD Signal Meter - Alignment	33
10.4	Peaking a Multi-Sat ODU.....	33
10.5	Peaking a Multi-Sat ODU with IRD signal meter	34
11	CUSTOMER EDUCATION.....	34
11.1	Remote Control.....	34
11.2	Operating the VCR with DIRECTV	34
11.3	Explain How to Record DIRECTV Programming.....	35
11.4	Explain How to Record Off Air & Cable Programming	35
11.5	Stereo Connection	35
11.6	Menus – Refer to Owner's Manual for Each Specific IRD.....	35
11.7	Additional Customer Information	36
12	MULTI-SWITCHES.....	36
12.1	Purpose.....	36
12.2	Types of Multi-Switches	36
12.3	Multi-Switch Functions	37
13	INSTALLATION TIPS / Common Installation Problems.....	37
13.1	Premature Rain Fade	37
13.2	Useful Equipment for Trouble-shooting:	38
13.3	Locate IRD's Main Menu and Perform "Systems Test"	38
13.4	Signal Strength	38
13.5	Additional Trouble-shooting Tips	38
14	TROUBLE-SHOOTING STEPS	39
15	RISK MANAGEMENT	39
15.1	Property Damage.....	39
15.2	Irate Customers	39
15.3	Customer Not Home	40
15.4	Late For Appointment ~ Greater than two (2) hours past the START of a window.....	40
15.5	Technician Responsibility	40
15.6	Clean Up After Installation ~ Small things make a big difference.....	40
16	APPENDIX A – STANDARD INSTALLATION STATEMENT OF WORK	41
17	APPENDIX B – CUSTOM WORK CHARGES	43

1 BASIC SATELLITE THEORY AND BACKGROUND

1.1 Key Elements

Four basic elements make up a satellite system:

- Programming/Carrier
- Uplink
- Satellite
- Receiving Equipment

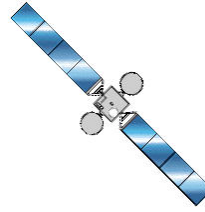

1.2 Programming / Carrier

Programming is software composed of audio and video information. The information is transported on the DIRECTV system in a compressed digital format. With digital compression, several channels can be placed in the space that was required for one analog signal. Satellites have channels, which are called transponders. Each transponder operates at a set and different frequency by using a carrier. Each carrier is modulated with digital information.

1.3 Uplink

Uplink is the name for the ground based satellite transmitter. It transmits the signal (Programming / Carrier) to the satellite. Transmissions are at microwave frequencies between 14 and 14.5 GHz. DIRECTV utilizes multiple up-link facilities and each broadcasts several carriers. To gather programming content, ensure its digital quality and transmit the signal up to the satellites, DIRECTV created two of the most sophisticated digital broadcast centers in the world — in Castle Rock, Colorado and Los Angeles, California.

Programming comes to the broadcast center from our content providers (CNN, ESPN, all local into local feeds, etc.) via satellite, fiber optic cable and / or special digital tape. Most satellite-delivered programming is immediately digitized, encrypted and up linked to the orbiting satellites. Some programs are copied to professional video servers by the broadcast centers' state-of-the-art automation equipment to be broadcast later.

DIRECTV first launched service in the summer of 1994. According to industry statistics, DIRECTV became the fastest selling consumer electronics product ever to enter the market — faster than color TVs, CD players and VCRs.

DIRECTV® programming is distributed by several high-power satellites.

All DIRECTV satellites are located in geosynchronous orbit 22,235 miles above the earth. DIRECTV provides service from three orbital locations under authority granted by the FCC: 101 degrees west longitude, 110 degrees west longitude and 119 degrees west longitude.

After DIRECTV is installed, a process that includes aligning the antenna to the satellites, no adjustment is necessary to change programming because the satellites remain in the same location in the sky. The antenna never has to track the satellites, so there's no waiting for the picture to come in and little maintenance is required.

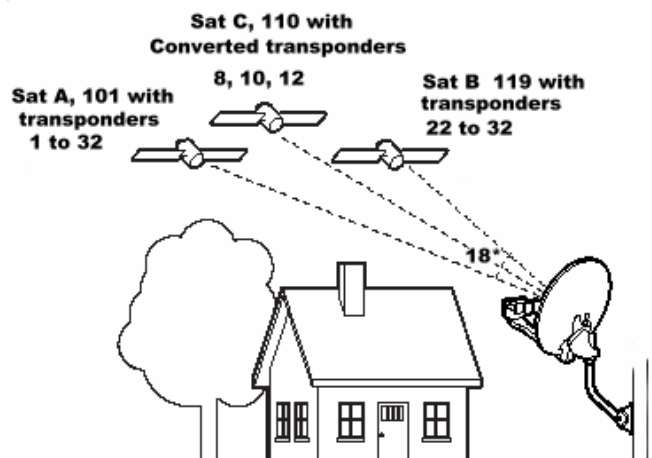

If you're familiar with multimedia computers, you may have heard of MPEG, which stands for Moving Pictures Experts Group. MPEG is a technology that can compress a moving image so it takes a tiny fraction of the space it normally would for transmission. Uncompressed digital images can be enormous; about ten or twenty seconds would fill up the hard drive on a home computer. Even compressed, digital moving images are very large.

Consider this comparison: Your modem can transmit information at up to 56 thousand bits per second. At DIRECTV, each of our transponders on the DIRECTV satellites can send about 30 million bits of information per second to a DIRECTV System or more than 500 times what a normal PC modem can handle. This data transmission rate enables DIRECTV to retransmit detailed moving digital video signals to subscribers. DIRECTV® programming and all DIRECTV Receivers employ MPEG-2 technology, the emerging world standard for digital broadcasts.

The DIRECTV satellite down link frequency is between 12.2 and 12.7 GHz. This "Footprint" is focused at one area. In our case, this area is the central portion of the continental United States. The area that the signal covers is called the footprint. The closer to the center of the footprint, the stronger the signal and consequently the smaller the ODU (Outdoor Unit) needed to receive an adequate signal. DIRECTV high power typically uses an 18" ODU.

1.4 Receiving Equipment

The receiving equipment is commonly referred to as TVRO, which stands for Television, Receive Only and does not have the capability to transmit. The components consist of an ODU (satellite antenna), LNB (Low Noise amplifier Block down converter), wiring and addressable IRD (Integrated Receiver Decoder).

The ODU is a Prime Focus Parabolic Antenna with an offset feed. The offset feed is considered more efficient than a center feed. The feed horn attached to the front of the LNB is focused to a common reflection point that collects the most signal. Since the signal at the feed horn is too weak to use, the LNB is placed immediately behind the feed horn to amplify the signal and convert it from KU Band to L - Band (950 - 2050 MHz.). This also allows the use of less expensive Series – RG-6 cable to feed the signal to the receiver.

The mount used by DIRECTV is an Azimuth over Elevation (AZ / EL) as opposed to a Polar Mount. The Polar mount is used when there is a need to move from one satellite to another. It tracks satellites across the arc of the horizon whereas the AZ / EL mount is used when the antenna is normally fixed on one satellite.

1.5 Satellite Link Analysis

The minimum availability of the DIRECTV signal should be > 99.7% without a degraded signal. This means that on an average the signal may be impaired for a maximum of 26.3 hours per year. The factors can vary depending on:

- Installation Quality
- Weather
- Clear Line of Sight
- Outside Interference

Installation quality is one factor that can have the greatest impact on the overall system performance. Errors include but are not limited to:

- Antenna Alignment
- Cabling / Connections (e.g. use of RG 59 / poorly crimped connectors)
- Signal Level

Any error within these areas will drastically reduce the availability of the signal to the customer and increase the possibility of a service call. As service calls increase, cost also rises and customer satisfaction decreases.

1.6 Creation of the DIRECTV System

DIRECTV was created to provide satellite delivered television service to consumers in the continental U.S. DIRECTV created an economical way to distribute video programming to areas cable TV systems could not cover.

1.7 DIRECTV Receiver Control Policy

DIRECTV Inc., in the interest of assuring the security and integrity of its encryption / decryption technology, has established certain fundamental policies. Distributors, Home Service Providers (HSP's), agents, installers and every employee are required to adhere to DIRECTV, Inc. Policies.

It is a violation of federal law to engage in (or to assist in) the manufacture, modification, sale or distribution of satellite receivers which permit the reception of encrypted programming without proper authorization. Penalties for such activities carry jail terms of up to five years and fines of up to \$500,000 for each violation. Such activity will also expose a party to civil liability of up to \$100,000 for each violation.

Inform every customer that the mere use of any equipment to receive programming without proper authorization is a violation of federal law. In addition, DIRECTV, Inc. will prosecute any parties who violate such laws, to the fullest extent of the law.

Distributors are required to notify DIRECTV Signal Integrity immediately at 800-830-6090 in the event they have knowledge or reason to believe that any parties are using or are attempting to use DIRECTV or any equipment for the unlawful reception of programming.

Notice

Under federal law, DIRECTV is vested with the right to prosecute a civil case and recover damages against any party engaged in signal theft activities.

It is the responsibility of each installer to assist us in our efforts to keep signal theft out of the home satellite market. If you have any questions about signal theft or DIRECTV, Inc. policies in this regard, please contact DIRECTV directly.

2 INTRODUCTION

All employees, contractors or agents, working for a DIRECTV sales agent, are required to follow the practices, procedures and standards found in this manual. Any variation from these standards requires prior written approval from DIRECTV technical operations.

It is imperative each person representing DIRECTV provide the best products, prompt responses to problems and courtesy to all DIRECTV customers. The installation technician, is often the only DIRECTV representative to have direct and personal contact with our customer.

The installer's efficiency, appearance and demeanor determine the customer's first impression of DIRECTV. It is therefore essential that the installer make a positive first impression that reflects well on him, his company and DIRECTV. It is the goal of DIRECTV for each customer contact to be exciting and friendly for the customer.

This manual will:

- Provide the information to ensure every installation is performed in an acceptable and professional manner
- Ensure the installation standards are followed and maintained in accordance with DIRECTV requirements

2.1 Pre-Call

- As a minimum, each customer must receive two (2) pre-calls from the Installation Company prior to any work being performed
- Contact the customer two (2) to three (3) days in advance of their scheduled installation to confirm both the appointment window and work to be performed
- Installer or dispatcher will phone the customer on the day of the scheduled appointment to confirm when they will arrive to begin the job. In the event that the agreed upon timeframe is in jeopardy, the customer must be contacted and notified of any changes.
- It is recommended that the customer be contacted within two (2) weeks post installation to confirm customer satisfaction

2.2 Identification

- The credibility of the installer and DIRECTV hinge on the first impression made with the customer
- The installer must look and be professional in his or her actions, appearance and the appearance of his or her vehicle. All DIRECTV installers should wear DIRECTV branded shirts and hats. Uniforms are preferred.
- All vehicles should be late model, appropriate for installation work, undamaged and have proper identifiable signage
- Upon arrival the installer should knock or ring the bell and step away from the door so he can be identified
- While greeting the customer the installer should smile and introduce himself
- The installer should show the customer proper identification
- The installer must remain polite and courteous at all times
- A picture ID card identifying the installer as a DIRECTV representative should be plain view or, at a minimum, carried and displayed at the initial introduction and upon request.

2.3 Verification

The installer will:

- 1) Verify services ordered and work to be performed with customer. Any non-standard / custom work with incremental costs associated must be communicated and agreed to in writing prior to commencement of installation.
- 2) Ask if there are any known restrictions on satellite antennas in the area or if permission is required from a homeowner's association or landlord. If the customer does not own the property, the installer should receive a copy of the Landlord permission prior to beginning work.

2.4 Pre-Installation Process

The installer will:

1. Involve the customer in selecting the best possible location for their DIRECTV antenna and the routing and placement of equipment.
2. Explain the different types of mount options and advantages / disadvantages and ask the customer for their location preference. (Having photos of other installations will greatly enhance this presentation and ensure the customer understands the differences.)
3. Always attempt to place the antenna and route the cable as inconspicuously as possible. (In locations where snow is common, an antenna placed on a high roof can be difficult or impossible to clean off.)
4. Confirm that the customer or a representative for the customer, who is at least 18 years old and authorized to sign for work performed, must be home during the entire installation. It should be noted on the Work Order if the customer plans to have someone represent them.

3 SITE SURVEY

3.1 Preliminary Evaluation

As you approach the work site, be aware of the following:

- 1) Trees, bare trees that will produce foliage in the future and landscaping
- 2) Any large obstructions or potential problems such as:
 - a) Fences
 - b) Fence gates
 - c) Water or gas wells
 - d) Any young trees that may grow into the line of sight
 - e) Construction in progress or potential new construction (new housing development, commercial complex)
 - f) Gardens and flower beds
 - g) Animals such as dogs or horses that may damage the equipment

➤ **NOTE:** *Once inside, ask the customer of any planned future projects that may affect placement of the DIRECTV ODU such as additions or pools.*

- 1) Note terrain: hilly, flat, wooded or clear
- 2) Type of neighborhood
 - a) Rural - vs. - urban
 - b) Residential - vs. - commercial
 - c) Generally zoned - vs. - Covenant-Restricted neighborhoods are more likely to have association restrictions
- 3) Location of house on property
 - a) Front or rear
 - b) North, South, East or West facing
- 4) Type of house
 - a) Style: ranch, raised ranch, colonial, split-level, etc.
 - b) Roof material type, condition and pitch
 - c) Type of siding: brick, wood, slate, etc.
- 5) Other structures to be aware of are:
 - a) Swimming pool or spa
 - b) Sidewalks or patio – especially in winter when they may be covered with snow
 - c) Deck
 - d) Other potential mounting structures such as garage, shed, barn or carport
 - e) Where electric and telephone service enter the home

3.2 Unobstructed Line of Sight

Use a compass and inclinometer to locate a site with an unobstructed view to the desired satellite(s).

Ensure that you have a 10-degree window around the charted location for the satellites. Remember the optimum window is for clear LINE OF SIGHT (LOS) from 10° left of the 101° satellite to 10° right of the 119° satellite. This is ~ a 40° window. If you only require LOS to the 101° satellite and the window will not allow the full 40° clearance, it is acceptable to proceed with the installation. Take into consideration future growth of trees that may impede the signal. If you cannot get a clear LOS, call your supervisor.

3.3 Ground Source

It is very important to access and bond the system to the best possible ground source (preferably the power ground). When looking for a site, the location of the ground is of utmost importance. The dish location should be coordinated with the ground source (keeping the ground as short as possible). If the house is not grounded, notify the customer and have them contact a Licensed Electrician. Contact your supervisor.

3.4 Access to Phone

Is a phone line behind the TV or will you have to install one? Will the phone line be run with the cable or by itself? Remember multiple IRDs must dial out on the same phone number. Check each phone jack to insure you are using the same number for all IRDs. Any install without a phone line requires the approval of your supervisor.

3.5 Distribution Location

Is there a location in the basement by the furnace or a utility closet that may be suitable for present or future multi-switches? A location indoors is always better than routing several cables around the exterior of the home.

3.6 TV Set Location

Is the TV located on an interior or exterior wall? What cable routing is best to the TV set location?

3.7 Customer Concerns

- 1) Always discuss the installation procedure, cable routing and antenna placement in detail with the customer before any work is performed.
- 2) If cable must be routed on the outside of the house, does the customer agree with your planned cable or phone wire route? (Always route cable through a basement, attic or crawl space before placing it on or around the exterior of the house).
- 3) Is your chosen antenna location going to be located where it would interfere with normal family activities or yard work?
- 4) Is the aesthetics of the installation in keeping with the structure and neighborhood?

➤ **Note:** *The account can only be activated by the person listed on the account*

3.8 Walk the Customer through the Installation in Detail

- 1) Cover the services to be installed as noted on the Work Order and amount due.
- 2) Provide the customer with an estimated completion time.
- 3) Discuss location of the ODU.
- 4) Discuss routing and entry of the cable and phone wire and note any holes that need to be drilled.
- 5) Confirm location of the IRD. ("This is where I would like to place the IRD. Is it OK with you?")
- 6) Discuss routing of cable or wire through the basement, crawl space or through the walls of the home plus any wires on the outside of the home.
- 7) Question the customer as to options, i.e. "Is it OK to bring the cable up through the floor by the TV?"

➤ **Note:** *Inspect all areas where you will be working for existing damage that you could be blamed for later. If you should find damages, bring it to the attention of the customer and have them acknowledge it in writing before performing any work in that area.*

- 8) Check the customer's TV, VCR and any audio system that is connected prior to doing any work. Do not assume that they are in proper working order. Always check the reception quality of all off air signals.

➤ **Note:** *Ask the customer (adult) to turn the TV set, VCR, etc. on and show you the channels they receive and how their system works. If you turn the set on and it does not work or has a problem, the customer may claim that you are responsible for the problem.*

- 9) Point out any TV set problems to the customer immediately and confirm if problems are new or existing. Explain that DIRECTV installations will not correct TV set related problems. They will receive better quality signals but DIRECTV will not correct a TV set problem.
- 10) Verify that the customer still wants DIRECTV installed. If so, make a note on the Work Order referencing the TV problem and proceed with the installation.
- 11) Follow established procedures regarding collection of any payment due. If payment is required, try to collect prior to installation. Always verify the amount and ask if payment will be by check or cash. This can alleviate potential problems; (e.g.) "My husband has the checkbook."
- 12) Other General Considerations:
- a) Do you have a clear view to the satellite?
 - b) Has permission been granted if customer is not the owner of the property?

➤ **Note:** *It is the customer's responsibility to obtain landlord permission for installation.*

- 13) Check for other restrictions: e.g., building permit required (depends on location – the burden is on the customer to obtain any such permits.) Refer to the zoning issues below.
- 14) Have the customer remove objects from the top of or around the television set and anything in any work area which could sustain damage while you are working.
- 15) Do not unplug anything for any reason without customer permission beforehand.

➤ **ZONING ISSUES (A BRIEF REVIEW)**

Installation location on property may mean special local zoning laws apply.

Zoning varies widely by community.

Covenants exist in some subdivisions. These are important but different from zoning laws.

Use good common sense!

3.9 Installation Overview - Standard Installation

23. As a minimum, each customer must receive two (2) pre-calls from the Installation Company prior to any work being performed. Contact the customer:
 - Two (2) to three (3) days in advance of their scheduled installation to confirm both the appointment window and work to be performed
 - Installer or dispatcher will phone the customer on the day of the scheduled appointment to confirm when they will arrive to begin the job. In the event that the agreed upon timeframe is in jeopardy, the customer must be contacted and notified of any changes.
 - It is recommended, that you contact the customer within two (2) weeks post installation to confirm customer satisfaction
24. Arrival at customer's residence within the designated window of time.
25. Completion of a site survey and planning the installation with the customer (Cable routing, antenna location, connection of devices). Refer to the DIRECTV Installation Manual - pages 3-1 to 3-3.
26. Verify services ordered and work to be performed with customer. Any non-standard/custom work with incremental costs associated must be communicated and agreed to in writing prior to commencement of installation.
27. Routing and properly attaching approved RG-6 cable through external and internal walls as needed. Routing of cable through attics and/or crawlspaces is considered standard. Refer to the DIRECTV Installation Manual - pages 4-3, 6-1 to 6-2.
28. Use of DIRECTV approved drop materials is required.
29. Grounding to meet Local / NEC requirements. Refer to the DIRECTV Installation Manual - pages 5-1 to 5-4.
30. Properly mounting to customer's home, aligning and peaking satellite antenna for maximum signal strength. Standard mounting includes, but is not limited to the roof, eave, outside wall, balcony, deck and chimney. Refer to the DIRECTV Installation Manual - pages 4-1 to 4-3, 10-1 to 10-3.
31. A Triple Sat ODU is required on all installations where local channels and / or high definition programming are delivered from the 110 or 119 degree satellites.
32. Running dual cable from the ODU to the ground block is recommended on all installs.
33. Dual cable **must** be run and connected to all DIRECTV DVRs.
34. Installation of one or more DIRECTV System IRDs as indicated on the customer's work order.
35. All IRDs must be connected to a land based telephone line. Refer to the DIRECTV Installation Manual - pages 7-1 to 7-2.
36. Connection of existing off-air antenna or active cable drop (enabling TV to function as it had prior to DIRECTV installation).
37. Connection of existing co-located devices (VCR, functioning surround sound, DVD, video games, etc.) and programming the DIRECTV Universal Remote Control to operate all applicable devices.
38. Completion of a system test verifying signal strength, access card match and telephone connectivity. Refer to the DIRECTV Installation Manual Page 13-1.

39. Activation of DIRECTV service with the customer on the phone.
40. Cleaning up any mess made during installation and removing debris from the customer's residence. This includes removal of empty equipment boxes at customer's request.
41. Customer education on system operation and features (min. 20 minutes). Refer to the DIRECTV Installation Manual - pages 11-1 to 11-2.
42. Completion of all applicable forms and obtaining customer's signature certifying the job was completed to their satisfaction.
43. Leaving installation company name and toll free telephone number if applicable with the customer enabling them to contact the Installation Company directly if there are any problems with the installation.
44. If, after arriving at a job the installation cannot be completed and is cancelled, the installer must explain to the customer in detail why they were not able to complete the job.

If you encounter any trouble with the install, contact your supervisor immediately.

REMEMBER: *It is the small things that make a great install and a great customer experience.*

3.10 Non-Standard Installation

The following are considered non-standard installation services

(Address added cost and prices with the customer prior to beginning the install):

- Yard or ground pole mount if requested by customer but not required for LOS
- Interior / Exterior wall fishes
- Mirror outlets (additional outlets)
- Line amplifiers or other accessories not included in the standard installation work order
- Sidewalk bore
- Any other situations that may incur additional incremental charges to customer

3.11 Safety Considerations

OSHA approved training is required for all contractors by DIRECTV and OSHA.

3.12 Working On Roof or Wall Mounts

- 1) Look for obstacles that might hinder movement of a ladder.
- 2) Look for overhead electrical, telephone or CATV wires.
- 3) Look for tree branches or clothes lines.
- 4) Use proper OSHA approved safety equipment like fiberglass ladders, lanyard and body harness.

3.13 Ground Mounts

Before you dig:

- 1) Locate and identify underground electric or gas utilities.
- 2) Locate and identify underground fuel oil or propane lines.
- 3) Locate and identify water lines, sprinkler or sewage system.

➤ **Note:** *Always ask the customer about any underground systems!*

3.14 Know Your Limitations!

- Do not attempt any procedure that you are not comfortable performing
- Call your supervisor for assistance
- Keep the customer informed of any problems. Never attempt to conceal a problem
- Do not attempt or perform unauthorized work
- As a DIRECTV representative, you are expected to perform only DIRECTV work

4 ODU INSTALLATION

4.1 Antenna Assembly

Refer to the specific ODU assembly manual included with every ODU for this application.

4.2 Wall Mounting – Wood

Locate a suitable wall to attach the base of the mount to using six lag screws (two 5/16" x 3" for the center holes and four 5/16" x 2" for the outside holes*).

A solid, clean, smooth surface will best facilitate the attachment of the mount base to the structure. Attach the base "plumb" using a torpedo level or post level and the mast will "plumb" much easier which will allow for a tighter alignment of the antenna. A shim may be necessary to achieve this when attaching the base to lap siding. (* - Attaching hardware is not provided with the Antenna Kit.)

Look for a row of nails attaching the siding to the house to easily locate wall studs or use a stud finder. Loosen the bolts located in the curved slot on both sides of the mast and move the mast to a 90-degree angle from the base to allow access to the center holes.

Align the two center holes in the base plate with the centerline of the stud (see diagram). With a pencil, mark the location of the top center hole on the mounting surface to indicate drilling point. Drill a 1/8" pilot hole at this location. Replace the base on the mounting surface and start one of the 5/16" lag bolts in the top center hole to hold the Uni-mount on the surface. Place a torpedo level alongside the base (from the top ear to the bottom ear), plumb the base on the wall and mark the location of the remaining five holes on the mounting surface.

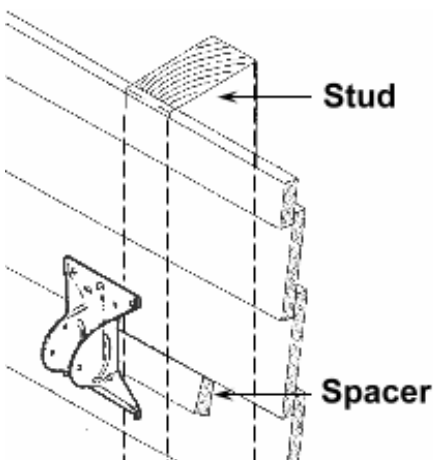

For ease of drilling, remove the one lag bolt and the base from the surface and drill the remaining pilot holes with a 1/8" drill bit.

To prevent water from leaking into the house, apply silicone sealant around each of the six pilot holes. Replace the base on the mounting surface and install the two 5/16"x 3" lag bolts with flat washers in the center holes. Next install the four 5/16"x 2" lag bolts with flat washers in the outside holes. Torque the six lag bolts.

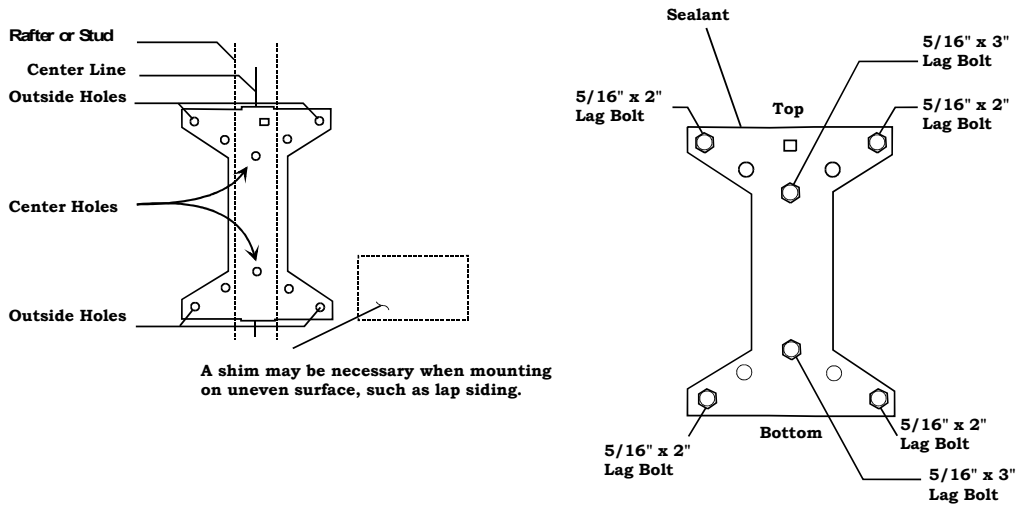

4.3 Brick Mount

Mount Installed on Brick or Masonry Wall

Base Mounting Bolts and Anchors not included with mount.

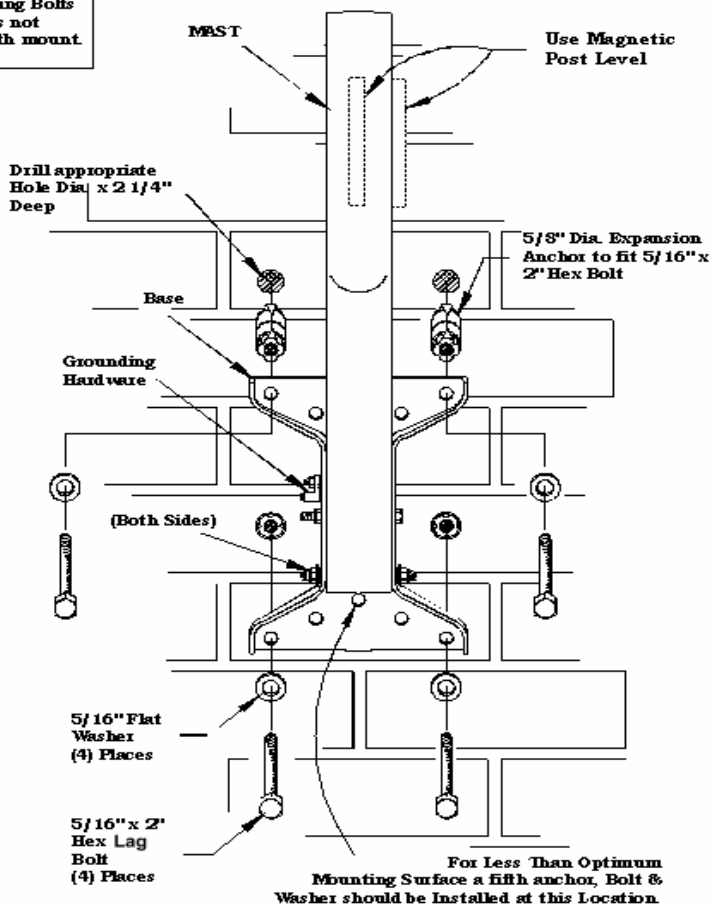

Locate a solid brick, concrete or block load-bearing wall, and make certain there are no protrusions preventing the Uni-mount from a flush attachment.

When attaching the mount to a brick or concrete wall, you will need four 5/8"x 2" lead anchors and four 5/16"x 2" lag bolts with flat washers. Place the base of the mount against the mounting surface with a torpedo level alongside the base as described above. Be certain that all four outside holes are located on a brick surface and not mortar. Mark the location of the four outside holes with a pencil.

Remove mount assembly from wall and pilot drill the four marked locations with 1/4" diameter x 2 1/2" deep holes. Drill the pilot holes out to 5/8" diameter x 2 1/2" deep and clean out holes. Install the four lead anchors flush with the surface of the brick. Seal with a silicone sealant.

4.4 Roof Mount Assembly

Use the mounting assembly for a roof application. Generally, this mount may be used only on asphalt shingled roofs. Normally the maximum pitch should not exceed 35 degrees but the universal mount can be installed on roofs with a pitch as high as 53 degrees with the proper safety considerations. **Do not install on roofs with wood, slate or tiled shingles.**

4.5 Positioning

Locate the rafters on the roof that faces southward and determine where the rafters are by using a tapping / listening method or reference point. To use the tapping method, you will need a hammer to tap across the roof area locating the center of the rafter. There will also be information for locating rafters in the manual that accompanies the ODU.

Attach the Universal Mounting Assembly using 5/16 X 3-inch lag bolts and sealing it with Bishops tape or tar patch. This mount can only be used on roofs and walls with a S, SE or SW facing surface and a clear unobstructed line of sight to the satellite. Roof mount procedures are the same as for the Wall with the exception of repositioning the mast foot. All unused holes will be sealed with silicon sealant. For further details, see manuals in each mount package.

4.6 Pole Mount - Hole Size and Location

Typically, the hole will be approximately 36 inches deep by 8 inches wide. The hole must be slightly wider at the bottom to prevent frost heave from displacing the pole during inclement weather. Place the flattened end of the pipe in the concrete to prevent rotation and attach the required ground wire to the punched hole. The pipe should extend at least 30" into the concrete pier. The use of "tall" poles is not an option.

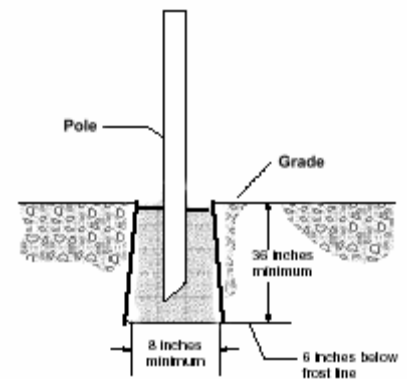

4.7 Concrete

The use of Fast Set concrete is a must if the installation is being done the same day as the pole is being cemented. It is acceptable to mix regular concrete and Fast Set 50 / 50 prior to pouring concrete into the posthole. If regular concrete is being used, it must be left to cure 24 hours prior to installing the antenna on the pole.

➤ **Install Tip:** Dig the hole and set the pole prior to digging the trench, cabling, grounding, etc. This way there will be more time for the concrete to set prior to placing the ODU on the post.

4.8 Trench / Drop Bury

- 1) Bury the drop cable to a minimum 6-inch depth or to a depth required by local codes. The buried RG-6 cable must be a minimum of 12" from buried electrical services (NEC 810.18 A). All direct buried cables must be rated for underground use.
- 2) Prior to digging the trench, ensure that there are no utilities in the proposed path. Mobile home parks and MDU projects can have many more obstructions.
- 3) The trench should be prepared in such a way as to eliminate sharp bends in the cable and minimize the impact on the environment. Remember that less than a 6" minimum bend diameter may damage the cable. Under extreme rocky conditions, conduit may be required to protect the cable from damage.
- 4) A service loop should be made at the ODU and be tie-wrapped near the antenna to protect it from damage and to conceal the cable.

➤ **Note:** Any cable that is direct buried must be flooded underground rated cable.

4.9 Cable Run

- 1) The cable must be run at right angles and follow the lines of the structure.
- 2) Do not attach the cable to the roof of the structure with clips, nails or screws that could later cause leaks.
- 3) Cable can NOT be attached to electrical entrance cables or electrical conduit.
- 4) Cable must be kept 4" away from electrical wires on the exterior of the home and 2" away on the interior.
- 5) Cable should be fastened every 18" on a horizontal run. Remember NO staples allowed.
- 6) Drip loops and a feed through bushing are required at all entry points to prevent water migration into the home.

4.10 ODU Assembly

- 1) Attach the AZ / EL to the ODU and torque to 4 PSF.
- 2) Insert and seat the feed support into the bottom of the antenna and torque the assembly to 6 PSF.
- 3) Mount the antenna assembly to the pole and align it to a southerly heading.
- 4) Route the cable up into the AZ / EL cap, leaving extra cable for subsequent maintenance. (One loop will be sufficient.)
- 5) The wire is then routed through the support ARM to the LNB.
- 6) For further details, see manuals in each antenna package

5 GROUNDING & BONDING

➤ **Pay close attention to this section.**

It is absolutely necessary for the DIRECTV System to be grounded to the electrical ground of the house. Our equipment should not be on a different ground potential than the house electrical system. If the grounding rules and guidelines are followed, proper grounding will be assured as will customer safety.

The NEC (National Electric Code) states that an outside antenna metal support structure must be bonded to the electrical ground of the house.

Ground the RG-6 messenger wire to the foot of the Universal Assembly Mount. There are several locations that the ground may be attached using the nut, washer and bolt provided. If the foot of the mast is not used, you may attach the messenger wire to the pole with an approved ground lug. These are the only acceptable ground options at the ODU. Never use the face of the ODU or adjusting bolts to ground the system.

The ground screw MUST never be used for any purpose other than for grounding. **Never attach to adjustment bolt that may be loosened at any point.**

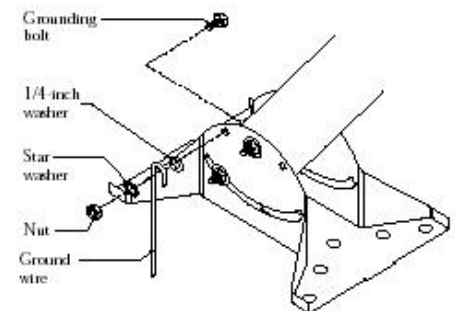
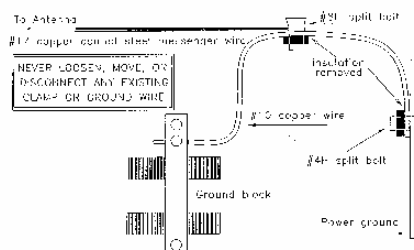

5.1 Ground Block

The length of the #10 wire from the ground block to the house ground should be as short as possible and in as straight a line as possible. Whenever possible it should also be shorter than the distance of the cable from the ground block to the IRD. The maximum length of the #10 from the ground block to the house ground is 20 feet. (NEC 820.40 subsection 4) Use only Green jacketed wire as approved.

- Attach the #17 wire from the ODU foot to the #10 wire with a #8H split bolt or connector that is NEC approved to accommodate more than one conductor.
See the dual screw ground block information below. The dual screw ground block is the preferred method for this connection

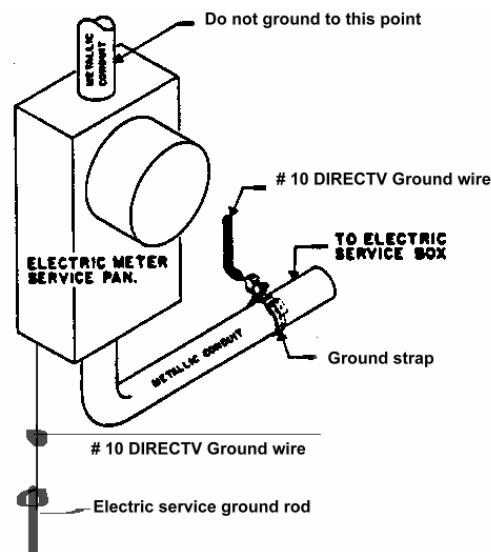
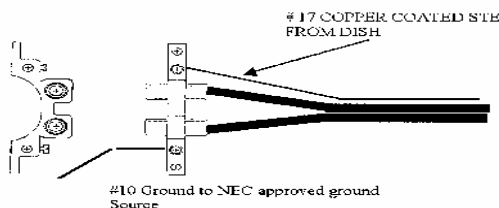

5.2 Suitable Ground Sources

When attaching the ground wire from the ground block (#10) to the house electrical ground system, several options are available depending on how the grounding system was originally installed. Below is a list of options currently allowed by DIRECTV based on NEC requirements:

- The #4 or #6 Ground electrode (wire) from the meter base to the electrical service ground rod
- The house ground rod (Separate Attachment)
- The panel box or breaker box ground lug stud
- The metallic service entrance raceway (metal conduit) attached from the meter base (customer side of the meter) to the first main disconnect (breaker box or cut off switch)
- The grounded metal FRAME of the building (commercial or trailer)
- Sprinkler system of a commercial building
- A grounded interior metal cold water pipe within five feet of the point of entry to earth

5.3 #4 or #6 Ground Wire to Electrode

This bonding source is preferred. It is easy to attach and usually easy to access. Remember to take sandpaper or something similar and scrape off any paint or corrosion that might have built up on the wire. This is required to make a good connection. Never do anything that would damage or weaken any ground wire. Use a split bolt to attach the #10 from ground block to the ground electrode wire. Wrench tighten the connection.

5.4 Electrical Ground Rod

The primary ground source of the house electrical system, (usually a ground rod) provides the best ground source. A proper and separate clamp (rated for burial) must be used in attaching the DIRECTV bonding wire to an electrical power ground rod. You may have to dig down a little to expose a rod. If so, it may be necessary to do some cleaning at the point of attachment to ensure a good connection.

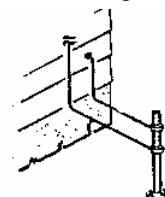

- *Note: Never attach the DIRECTV bonding wire to the existing clamp and never loosen any clamp when attaching the ground. This can be very dangerous as the electrical ground wire can have voltage and high current and this will sacrifice the integrity of the existing ground.*

5.5 Panel Box Lug or Meter Base

On some meter bases and panel boxes (breaker boxes), there is a stud, usually at the bottom, where a lug can be attached to provide a grounding point for DIRECTV. If the box or panel does not have this stud, a corner clamp will allow you to attach the bond wire to the back corner of the box.

This clamp must be attached at the rear of the meter pan.

Some power companies will allow this, but you will need to be sure. Contact your local power provider to verify. It is imperative that this clamp can in no way impede or restrict removal of the electric meter cover.

➤ **Note:** *Use this clamp only as a last resort.*

5.6 Metallic Service Raceway

This option may be used if there is no electrical ground conductor available to attach to, or if it is further away than the metallic conduit. It is preferable to utilize this option when the metallic conduit is the service entrance conduit and is continuously unbroken between the meter panel and the first main disconnect panel.

This type of connection will need to be made with an approved galvanized grounding strap (Sachs); 6-inch or 12 inch, depending on the diameter of the metallic conduit. The surface of the metallic conduit will need to be cleaned with sandpaper to provide a clean connection.

5.7 Grounded Metal Structure (Mobile Home)

The metal structure of a commercial building or a mobile home by NEC is a ground source and can be used only under the situations outlined in the below diagram. Use an approved beam clamp and take care to clean the metal where the attachment will be made to ensure a good connection.

Also, take care to check that the structure is indeed bonded to the electrical ground. This may be done with a continuity check (using a VOM).

It is best to connect to the I-beam, which is directly grounded to the breaker box. Connection to breaker box must be verified – on doublewide mobile homes, the jumper between the two frames must be present. When using this attachment, the meter pole must be more than 30 feet from the trailer.

5.8 Sprinkler System – Commercial Buildings

When cabling a commercial complex, another ground source can be the fire sprinkler system. This option will offer a ground source, but use it only as a last resort. Remember to scrape off any paint, coating or corrosion on the pipe to be sure it is clean and a good connection is made.

5.9 Metal Underground Water Pipe

Water pipes should not be used for grounding if the point of connection is more than 5' from the point the pipe enters earth. See section 250.52 of the NEC below.

Section 250.52 of the NEC states: A metal underground water pipe in direct contact with the earth for 3.0 m (10 ft) or more (including any metal well casing effectively bonded to the pipe) and electrically continuous (or made electrically continuous by bonding around insulating joints or insulating pipe) to the points of connection of the grounding electrode conductor and the bonding conductors. Interior metal water piping located more than 1.52 m (5 ft) from the point of entrance to the building shall not be used as a part of the grounding electrode system or as a conductor to interconnect electrodes that are part of the grounding electrode system.

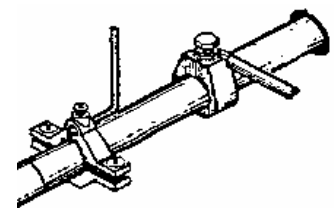

5.9 Supplemental Electrode Bonding Ground Rod

In most cases, careful planning of the installation will eliminate the need for supplemental electrode bonding.

Changes in the 2002 NEC code have reduced the maximum length of the #10 ground wire to 20 feet. In order to minimize the cable loss, this alternate bonding method may be required.

When the electrical ground is over 20 feet from the ground block, the following method for bonding will enable you to complete the installation by NEC requirements. (NEC 820.40 subsection 4)

The below list provides a step-by-step grounding process. Keep in mind this is a last resort for a ground source.

- 1) Once a suitable position is found for the ODU and the ground block, a ground rod will need to be driven into the earth within 20 wire feet of the location of the ground block.
- 2) The type of ground rod to be used is an 8 ft copper coated steel rod. The rod is required to be driven 8 ft into virgin soil. Dig a small hole a couple of inches down. Drive the ground rod except for the last 6 inches.
- 3) Once attachments are made, drive rod in below ground. This requires digging out around the clamp area so the clamp will not be disturbed when rod is set below ground level.
- 4) Use a ground rod clamp to attach the #6 to the ground rod. The #10 from the ground block may be attached to the #6 with a split bolt connector. The other end of the #6 must be connected to the electrical service ground conductor, (wire) or the electric service ground rod.
- 5) The #6 will be run to the house ground either underneath the house or buried if the house is built on a slab.
- 6) At the house electrical ground, the #6 can be bonded either to the house ground electrode with a split bolt rated for two wire connection or to the electrical ground rod with a separate ground rod clamp approved for burial. There are several things to keep in mind when using this method:

- Only one wire may be attached to each ground rod clamp
- This is a good option when the placement of the ODU is restricted by the landscape, the location of trees in the yard or the location of the house ground. Some ground sources are located on a pole far away from the house.
- This method can also be used to wrap a #6 wire around a row of apartments or condos where the electrical service and meters are at one end of the building. The ground rod should be placed at the opposite end from the electrical with the #6 between and the #10 attached to the #6 at each residence for bonding.

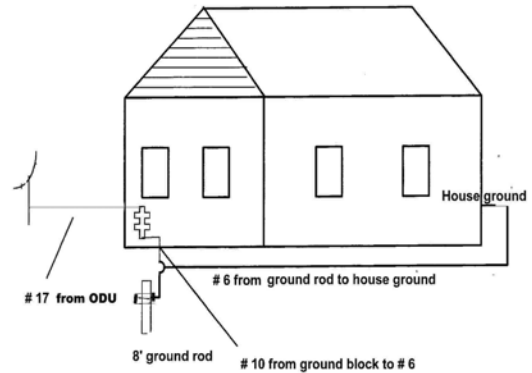

5.10 Summary of Grounding

This is an extremely important step in the DIRECTV installation. If done correctly, it will provide protection against electrical shock for the customer. To ensure the continuing integrity of the grounding system you have setup at the customer's house, it is essential to attach a green ground warning tag at the connection to the house ground. This will tell the customer or any service technician to contact DIRECTV if the need arises to disconnect our ground from the grounding system of the house. Remember when configuring the ground run, the length of the ground wire must be as short as possible.

➤ ***"DANGER: Never disconnect the house ground connection in attempts to connect your wire to the house grounding wire."***

➤ **Note:** Changes in the 2002 NEC code have reduced the maximum length of the #10 ground wire to 20 feet. NEC code. (NEC 820.40 subsection 4)

➤ **Always** comply with Local Electrical Code Requirements. For example the green ground warning tag may not be required when using #10 green coated ground wire.

6 CABLE ROUTING

After deciding the location of the IRD(s), plan the routing of the cable. Several things should be considered:

- 1) What type of house is it?
- 2) Is it one or two story?
- 3) Is the foundation conventional or slab?
- 4) What type of siding is used?

When choosing a location for the ground block, choose one that is as close as possible to the house electrical ground to promote a short ground run. If feasible, also place it close to the point of entry for the cable run into the house. Once these are determined, it will be a matter of finding the shortest / best route to the TVs.

6.1 Conventional Foundation

- 1) If the house is on a conventional foundation (basement or crawl space), the cable should be routed underneath the house for aesthetics. If this is the method chosen, make sure that the cable is not left lying on the ground.
- 2) Attach cables up to the underside of the house by using dual clips or drive rings. If the cable route is through a basement, the cable should be through or attached to the joist but should not be attached to the bottom of a joist. If the cable is to be routed through the attic, use a feed through bushing sealed with a silicone sealant at the point of entry. The cable shall be sealed with a silicone sealant to the bushing.
- 3) Take care to place the cable out of the way of traffic or away from anything that might damage it. Always fasten cable up out of the way to protect it. Preferred method is over ductwork and piping. Use caution around hot water pipes and hot water heat pipes. Cable lying on a hot water pipe can be damaged. Cable must have a 2-inch clearance from internal electrical wire.

6.2 Slab Foundation

If the house is on a slab foundation:

- 1) It is preferable to route the cable through the attic for aesthetic reasons.
- 2) The less showing on the outside, the better. If this is not possible, run the cable along the lines of the house, up either along the eave of the house or along the bottom where it will be easy to hide behind the shrubbery.
- 3) When tacking the cable along the outside of a house, space the clips evenly so they are uniform and the cable maintains a straight line, not sagging. Recommended spacing for clips is 3' vertical and 12 to 18" horizontal.
- 4) Use caution not to crush or compress the cable when installing cable clips.
- 5) When running cable around corners, take care not to kink it in any way. Keep the bend radius (5-inch minimum diameter) in mind.

6.3 Cable Considerations

The proper type of cable must be used for each type of situation. All cables must be Series RG-6, sweep tested to 2050 MHz with a loop resistance of 2 ohms or less and solid copper center conductor. In addition, cable must be UL approved and meet CL2 and CMX ratings.

- 1) Cable running from the ODU to the house shall be Series RG-6 Dual cable with #17 copper clad steel ground wire attached for bonding. This cable should never be spliced. No underground splices are permitted. Any cut cable must be entirely replaced.
- 2) The run from the ground block should normally be non-flooded cable. It may be necessary to run flooded if part of the run will need to be buried. In these instances the cable must be converted back to non-flooded cable before it enters the living area of the home in another house box (on the outside) or behind the wall plate on an outside wall. If the cable enters the basement, a ground block may be used as a transition device.
- 3) If a trailer is being installed, avoid bringing cables inside through the wall; instead always bring cables up through the floor. If this is not possible (outside wall), then drilling through the wall may be the only option. Care must be taken to avoid electrical wiring. At the point of entry, use a feed through bushing with silicone sealant.
- 4) When bringing the cable in through a wall or down a wall from the attic, use a wall plate to bring the cable into the room. As a standard install, you can always use a 24-inch drill bit to drill down through the wall from the standard electrical outlet height down through the sill plate in the basement or crawl space. (This should be considered normal installation and NOT a wall fish).
- 5) When the cable is brought up through a non-carpeted floor and the hole is larger than the cable, use a feed through bushing to seal the entry point. (e.g., 5/8" hole for dual RG-6 cable)
 - a. When the floor is carpeted, it is necessary to properly prepare the carpet for drilling. The recommended method is using a carpet punch. At a minimum, the carpet must be pulled back or out of the path of the drill bit.
 - b. Be sure the customer understands you will be placing the cable through the carpet. Do not try to drill through the carpeting as this may cause the carpeting strands to get caught on the drill bit and will snag the carpet and cause damage.
- 6) The ground block should be located outside whenever possible.
- 7) When bringing cable inside a structure, into the basement or attic, the method of drilling may differ. Always drill at an angle so that the outside hole is lower than the inside hole to prevent moisture from entering the wall space.
 - a. If drilling into the basement, it may be best to drill from the outside in.
 - b. If drilling into the room where the IRD will be, it is usually best to drill from the inside out for hole placement.
 - c. Any time the cable runs down an outside wall or entering from above the hole into the house put a drip loop at the hole to prevent water from entering the wall. The loop in the cable must be at least a 4" diameter.



7 TELEPHONE LINE INSTALLATION AND TROUBLE-SHOOTING

Connection of the receiver to a telephone line is **mandatory**. Every effort must be made to connect the receiver to the customer's telephone line. In the event that a customer doesn't have a telephone, DIRECTV does have the ability to authorize the unit in a "non-impulse" mode. However, programming packages available to the customer are limited as not all services can be provided to a receiver not connected to a telephone line. Pay per view purchases must be made by calling customer service and are therefore more expensive than standard impulse purchases when no telephone is connected to the IRD. **This information must be communicated clearly to the customer prior to beginning the install.**

The telephone connection gives the customer the ability of purchasing PPV events by using the remote control (impulse PPV). It also gives DIRECTV access to IRD information, such as signal quality and the signal history for trouble-shooting. At times, customers will not want the line connected to their IRD or they will not have telephone service. If they have no service, then the telephone line should still be installed and connected to the IRD in case they acquire service later.

7.1 Installation

The preferred method is to homerun the telephone line directly from the IRD to the demarcation point outside the house if a modular jack is not available.

- 1) Always check to see if an existing modular telephone jack is close to the IRD. This requires a duplex telephone jack so the customer has telephone access at the jack. If the jack is not in close proximity to the IRD, then make sure any jumper you install will not be in the way of any door or walking path.
- 2) Installation must be completed with approved telephone station wire. Install a biscuit jack or combination wall plate behind the TV and use a modular telephone jumper to connect the jack to the IRD.
- 3) In some cases, it may be necessary to attach the station wire to an existing outlet. This is allowed when a home run is not practical; however, under no circumstances should the customer's wire be cut. The wire must be connected to an appropriate connection in the existing outlet.
- 4) When connecting the telephone line to the terminals in the outside box, always observe correct polarity (red and green).
- 5) Be careful not to disturb existing telephone connections.
- 6) If the telephone line is installed underneath the house, be careful not to let the wire lay on the ground. It will need to be tacked up along the underside of the house to prevent possible damage
- 7) If the phone line is attached along the outside of the house, run it along the lines of the house. Always try to keep it as well as the coax concealed as much as possible. It is sometimes feasible to run the telephone line underneath the coax thereby concealing it completely. The feed through bushing has a notch in it for routing of the telephone line with the coax. This will eliminate the need for an extra hole to be drilled.
- 8) Biscuit-type telephone jacks can be attached with double-stick foam tape that comes with them or attached directly to the wall with screws.
- 9) Another type of wall jack available has both the telephone and coaxial connection mounted on a wall plate. This device is attractive because it does not require a separate wall outlet for the phone connection; in most cases it requires installing a low voltage bracket in the wall.
- 10) Make sure the customer understands the telephone line must be connected to the IRD at all times to assure trouble-free service.
- 11) Never splice a telephone line

- 12) Never bury a telephone line that is not rated for direct burial. This type of wire has a thick black insulator type jacket and a flooding compound. Under no circumstances is the station wire to be plugged directly into the receiver by attaching an RJ-11 modular connector directly to the station wire. Modular connectors are designed specifically for satin modular phone line.
- 13) When attaching the wires to the screws in the jack or the house telephone box, never wrap the wire all the way around the screw post overlapping it back onto itself. This can cause the wire to be cut when the screw is tightened. After installation, always check every phone line in the customer's home to ensure all lines are working.

7.2 Trouble-shooting Phone Lines

Many things can affect the operation of the telephone circuit connected to the DIRECTV System. Use the following trouble-shooting steps. If all trouble-shooting fails and no corrective action is found you may be forced to install the IRD as non-impulse.

- 1) Check to make sure the phone line is connected to the receiver.
- 2) Run a system test. If phone line "not okay," connect a telephone in phone jack and check for dial tone.
- 3) If there is a dial tone, replace IRD with a different receiver and run system test.
- 4) Check on hook voltage to be sure it is greater than 17 V DC. Typical voltage is ~50 V DC. This is done by reading across the red and green, tip & ring, of the phone line with a multi meter on DC volts.
- 5) Check off hook voltage by taking a phone off hook and reading the voltage the same as above. Off hook voltage must be less than 11 V DC. Typical off hook voltage is ~5 VDC.
- 6) If there is not a dial tone, contact local telephone company.

7.3 Valid Reasons for Non-Impulse IRDs

- No phone service, however, a phone line should still be run and connected to the phone demarcation point
- Customer objection only after explanation of the benefits and drawbacks for non-impulse. Customer MUST sign off.
- Phone line not available or not practical to run. If not practical to run, must be approved by supervisor and specific reasons noted on the Work Order. Wireless phone systems are not an option for all advanced product (e.g. TiVo, Ultimate TV) installations.
- IRD failed the phone test and problem cannot be corrected. Details as to why phone test failed and specific trouble-shooting steps noted with voltages.
- Party line with operator intervention
- 800 block on customer's line

8 ACCESS CARDS

An access card is included in the purchase of a DIRECTV System and authorizes the programming for the customer's system. Once the customer has completed their DIRECTV System installation, the access card is added to the customer's account and services are authorized.

Access cards are non-transferable. They cannot be transferred from one customer or dealer account to another.

9 INTEGRATION WITH THE CUSTOMER'S EQUIPMENT

Key Points:

- 1) The coaxial RF output used to connect the IRD to the customer's TV does not provide an MTS stereo signal. If the customer has a stereo light or indicator on their TV, it will not indicate stereo even though the TV is receiving stereo. **Connection preference order: Component, S-Video, Composite, RF.**
- 2) The L-R audio outputs (RCA Connectors) will provide stereo signal to the TV / VCR and the output level is fixed at 1 V P / P. Volume is controlled by the customer's TV or audio system if applicable.
- 3) To use the IRD's composite video and audio outputs to the TV, the TV must be capable of receiving this type of input and it **must be set to the correct Video Input mode**.

➤ **Note:** *This generally means that the stereo indicator on the TV will not light up even though the TV is receiving true stereo. The only time this light works is when the MTS stereo signal is being decoded by the TV from another source (i.e. off air antenna or cable).*

- 4) As above, if the VCR is connected to the IRD using the audio and video jacks and the customer wishes to record in stereo, then the VCR will need to be set to the correct input. This input is usually labeled as Line 1 or Line 2, VIDEO or AUX., depending on the number of inputs the particular VCR has as well as its make and model.
- 5) The IRD's S-Video output provides the best picture quality but the TV and / or VCR must be equipped with an S-Video jack. This requires a special cable that is not provided with all DIRECTV receivers. The S-Video output does not provide any audio output so the L-R audio jacks must be used in conjunction with the S-Video jack. Again, the TV and / or VCR must be set to the correct input mode to accommodate this hookup.
- 6) The RF antenna input will only accommodate a 75-ohm cable. If the customer's antenna line is the 300-ohm type, (flat cable) then a 300-75 ohm transformer will be necessary.
- 7) Set the channel selector switch located on the back of the IRD, to the same channel as the TV and VCR. These outputs have a fixed output level to facilitate proper use with VCR and stereo hookups. Some IRDs have a programmable output that is changeable through the IRD installation and set-up menu.

9.1 Tuning VCRs

It is important that all new customers understand that recording procedures require that their VCR be tuned to the same channel the output on the IRD is set for. Set the IRD RF output for whichever channel, (either 3 or 4), that is not used for local programming.

To check for proper tuning – with the TV and IRD on, turn the VCR on and set the channel display on the VCR to the same channel the output of the IRD is set for (Channel 3 or 4). Press the TV / VCR button on the VCR. If the picture flicks but you do not see any significant change, then the VCR is properly set. If the picture goes to snow, blue screen or junk, then you need to tune the VCR with the VCR tuner.

e.g. IRD = Ch 4 → VCR = Ch 4 → TV = Ch 4

Remember the VCR can also record from one of the Line inputs for better quality recording.

9.2 Stereo / Surround Sound

Most customers now have television sets equipped for stereo sound. Some will have a stereo audio system in addition to a stereo TV. It is essential that this equipment also be connected.

➤ **Note:** *The customer must have a stereo receiver that is capable of processing the surround signal in Dolby Digital format. This does not mean that they can't enjoy the stereo signal that most receivers can process.*

➤ **Note:** *Never connect an audio wire when the equipment is on!*

Always check the following for proper stereo hookup:

Verify that the customer's stereo receiver has available inputs for the IRD audio output. Most will have inputs labeled 'aux. input' or, if that is not available; you may use an input such as 'CD input' or 'tape input' if it is not being used.

➤ **Note:** *Under no circumstances should you ever connect the IRD audio to the PHONO input of a customer's amplifier. This usually causes severe damage to the amp and / or speakers.*

- 1) Depending on which input is used, the stereo receiver will need to be set to the correct input selection to receive the audio signal from the IRD.
- 2) When connecting the IRD to the stereo, the L&R audio outputs will be used.
- 3) These closely match most VCR's audio output levels and all volume control is done with the customer's stereo system.
- 4) Not all movies are encoded with the Dolby Digital & Surround Sound format. Make sure the customer understands this to avoid unnecessary service calls.
- 5) If the customer has a hi-fi VCR, it is usually best if you connect the audio output from the IRD through the VCR's audio in and then out of the VCR to the TV or stereo receiver. This will allow the customer to have surround and / or stereo sound from both DIRECTV and their VCR.
- 6) If the customer has a TV or Sound system that has multiple inputs and outputs for audio and video, these usually act as a control center and all in / outputs should be connected through this device.

True digital stereo sound can still be enjoyed even if the customer does not have a surround sound receiver. Again, whenever possible connect the IRD to the customer's stereo equipment. Detailed quality instruction should also be given to the customer on the system operations.

9.3 Picture-in-Picture (PIP)

Many television sets now come equipped with the PIP feature (watching two or more programs at the same time).

Most TVs with PIP require the additional input signals be supplied as base band audio / video signals. This signal can be provided by a variety of sources (e.g., DVD, Laser Disc or a VCR).

Newer high end TV / Monitors now allow multiple RF inputs as well as multiple A/V, composite and component inputs.

Television sets that offer PIP differ in how each picture is displayed. With this in mind, the customer may need to consult the owner's manual on PIP operations. Unless the customer requests otherwise, set up DIRECTV as the primary signal since it is usually the main video source. This also helps a great deal when trouble-shooting over the phone.

➤ **Note:** *Even if a customer has picture in picture, they will only be able to receive 1 DIRECTV signal at a time unless they have an advanced product IRD or two (2) IRDs connected to the PIP TV.*

9.4 (HDTV) High Definition TV

In order to receive HDTV signals, you must have an HDTV receiver as well as an HDTV television / monitor.

The connection between the HDTV IRD and the HDTV must be made with the best available connection (listed in descending order of preference): 1. DVI connectors, 2. RGB connectors or 3. Component connectors. The channel 3 / 4 connection should always be made for trouble-shooting purposes.

A multi-sat ODU must be installed in order to access HDTV programming on the 110 / 119° satellites. If an older ODU is in place, make sure the c- kit is installed for the 110 feed.

Note: As of July 1, 2003 the DIRECTV High Definition programming package contains four national HD networks (all on the 110 satellite):

ESPN HD	Channel 73 (ESNH)
Discovery HD Theater	Channel 76 (DSCH)
HDNet	Channel 79 (will be mirrored to 198 until 9/1) (HDN)
HDNet Movies	Channel 81 (HDNM)

In addition, the package offers complimentary viewing of "Special Event" programming such as The Master's Tournament, select NBA regular season and playoff games. These special events are available on Channel 84 (SPHD).

The following existing stand-alone HD programming does not require purchase of the HD Package:

PPV Movies	Channel 198 (will be moving to Channel 85)
HBO & Showtime	(require purchase of premium network programming)
HBOH	Channel 88
SHOH	Channel 91

NFL – Purchase of NFL Sunday Ticket provides "Special HD Free Preview" for 2003 Mega March Madness games broadcast in HD

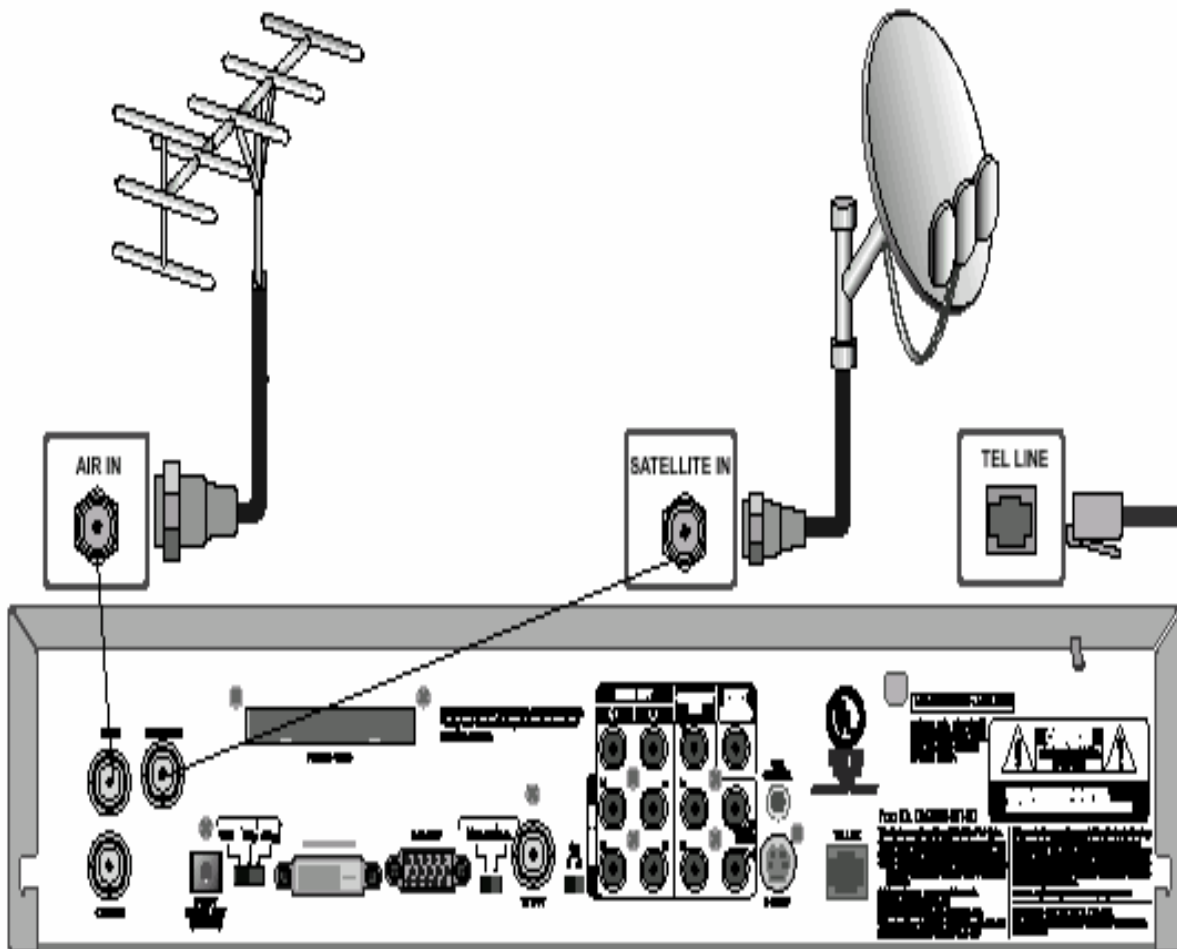

10 ODU ALIGNMENT AND PEAKING

10.1 General

The ODU can be peaked by using a satellite signal strength meter (preferred) or the built in signal strength meter in the IRD.

Prior to attempting alignment and peaking, the following must be established:

- Clear line of sight
- Antenna and mount installed and pole plumb
- System connected to IRD with IRD plugged into active electrical outlet. Access internal installation and set-up menu to determine appropriate azimuth and elevation settings.
- ODU type has been selected in the IRD installation and set-up menu

10.2 Signal Strength Meter – Alignment

- 1) Connect the signal meter between the LNB and the receiver. Use a temporary jumper ~ 3' long from the LNB to the meter.
- 2) In order to supply power to the meter and LNB the receiver must be installed and connected to a live electrical outlet or use a battery pack. The meter will pass power through to the LNB.
- 3) Set the elevation adjustment to ~ 4 degrees below the recommended setting for your area.
- 4) The ODU should be moved to the approximate azimuth for the zip code that you are installing in and then panned slowly to the left or right approximately 5 degrees. The meter should be set up to monitor signal strength at this point.

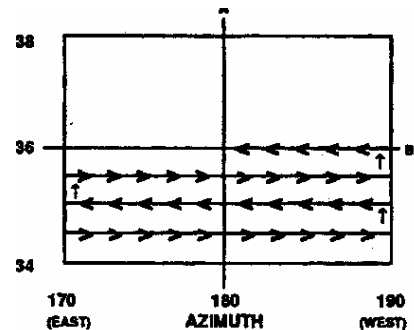
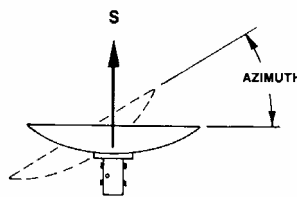
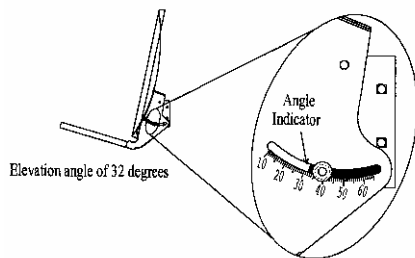
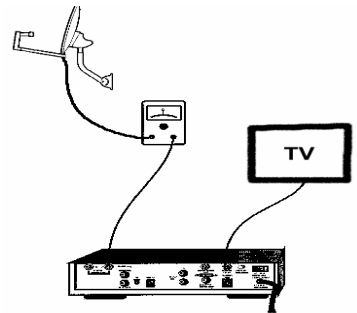

- 5) Pan the ODU in the direction of the expected azimuth angle slowly and monitor the meter for signal. If the ODU is moved 5-8 degrees past the expected azimuth and there is no signal, the elevation should be increased two (2) degrees and the sweep repeated. If signal is not acquired, the ODU elevation should be lowered an additional two (2) degrees and the sweep repeated. If acquisition is still unsuccessful, the ODU elevation should be raised two (2) more degrees and the sweep repeated. If no signal is found by this point the elevation should be reset to the expected degree and the process should be restarted.
- 6) **If there is no signal after repeating this entire procedure, consider checking the plumb of the pole, meter settings, connections, LNB power / functionality and, field of view. Note that the farther you get from your expected settings the more likely you are to acquire an incorrect satellite. Remember to call your supervisor if you need help.**

- 7) Once the satellite signal is identified, the fine peaking process begins.
- 8) The azimuth should be peaked first by moving the ODU left or right slightly to maximize the signal on the meter. When performing this step, the ODU should be moved past the peak signal and then reversed to the maximum reading. The ODU azimuth bolts should be tightened at this point enough that the ODU will not easily swing left or right.
- 9) The elevation is set by adjusting the ODU up or down past the peak signal and then back to the peak signal setting. The elevation bolts should be tightened enough at this point to hold the elevation setting temporarily.
- 10) The final step to ensure peak signal strength has been achieved is to lightly push and pull the top of the ODU. If the elevation is maximized, the signal will go down. If it does not, the elevation bolts should be slightly loosened and re-peaked vertically.
- 11) The same test is performed to the left and right and should give the same results. Again if it does not, the azimuth bolts need to be loosened slightly and re-peaked in this plane.
- 12) Once you are confident the ODU is properly peaked, tighten the left and right pivot bolts in alternate sequence, making sure that the voltage or signal strength does not drop.
- 13) Torque to specifications noted in ODU manual and recheck signal to ensure that it has not dropped.
- 14) Remove the meter and connect the cable to the LNB.
- 15) Return to the receiver and check signal quality to ensure it is within specifications for your area. Re-peak if signal is not >80 or consistent with your area.
- 16) **Use a permanent marker to place a vertical reference alignment mark on the AZ / EL cap to the pole. Never scratch the paint, as this will cause the pole to rust.**

10.3 IRD Signal Meter - Alignment

Exact steps to selecting the signal strength meter varies by manufacturer, however the general procedure is the same.

- 1) Use the IRD menu to access the installation menu screen.
- 2) Select the signal strength meter option.
- 3) As you have not yet peaked the ODU, the signal strength meter is probably reading 0.
- 4) Refer to section 10.2, step 3 above and follow the same procedure as peaking with a signal strength meter for actual ODU alignment steps.

10.4 Peaking a Multi-Sat ODU

- 1) Go into the IRD installation & set-up menu and select the appropriate ODU type. Remember that the azimuth and elevation settings provided are for the 110 slot. You must calculate accordingly to determine the settings for the 101° and 119° coordinates (+/- 9°).
- 2) The multi-sat ODU requires that the azimuth, elevation and tilt be set for both the A (101) slot and the B (119) slot. When these are peaked, the C (110) LNB (if applicable) is automatically peaked due to the construction of the ODU.
- 3) The azimuth of the Multi-sat ODU should be peaked first by panning the ODU left or right slightly to maximize the signal on the meter. The 22 KHz tone should be turned off at this point to peak the A (101) LNB. When performing this step, the ODU should be moved past the peak signal and then reversed to the maximum reading. The 22 KHz tone should be turned on and the step repeated for the B (119) LNB. The meter should be switched back and forth from A to B and back until both LNB's signals are maximized. The ODU's azimuth bolts should be tightened enough at this point that the ODU will not easily swing left or right.
- 4) The elevation of the Multi-sat is set by adjusting the ODU up or down past the peak signal (and then back to the peak signal reading). The 22 KHz tone should be turned off. When performing this step, the ODU should be moved past the peak signal and then reversed to the maximum reading. The 22 KHz tone should then be turned on and the step repeated for the B (119) LNB. The meter should be switched back and forth from A to B and back until both LNB's signals are maximized. The elevation bolts should be tightened enough at this point to hold the elevation setting temporarily.

- 5) The tilt of the Multi-sat ODU must also be peaked (with the 22 KHz tone turned off). As in previous steps, rotate the ODU clockwise or counterclockwise while passing peak signal and then back to the peak signal setting. The 22 KHz tone should then be turned on and the step repeated for the B 119 LNB. The meter should be switched back and forth from A to B and back until both LNB's signals are maximized.
- 6) The final step to ensure peak signal strength has been achieved is to lightly push and pull the top of the ODU. If the elevation is maximized, the signal will go down. Turn on the 22 KHz tone and repeat for the B LNB. If the signal doesn't go down, the elevation bolts should be slightly loosened and the ODU re-peaked vertically.
- 7) The same test is performed horizontally and rotationally. All tests should give the same results. If it does not, the bolts need to be loosened slightly and re-peaked in the plane which needs improvement.
- 8) After performing these final steps, all ODU hardware should be tightened while monitoring the meter to make sure the signal remains at its maximum level.
- 9) Remove the meter connections, reattach the LNB if it was disconnected and continue with the rest of the installation.
- 10) Verify signal strength on all satellites by utilizing the installation screen on the DIRECTV receiver. Verify the 101° satellite by checking channels: 100 = (Odd transponder) and 200 = (Even transponder.)
Verify the 110° by checking channel 90
Verify the 119° satellite by checking channel 400
- 11) **Use a permanent marker to place a vertical reference alignment mark on the AZ / EL cap. Never scratch the paint, as this will cause the pole to rust.**
- 12) Document the signal strength on the work order and in the customer's IRD owner's manual.

10.5 Peaking a Multi-Sat ODU with IRD signal meter

- 1) Follow manufacturer's instructions to enter signal strength measurement menu.
- 2) Preset elevation and tilt / skew.
- 3) Sweep Az & lock on Sat A.
- 4) Maximize Sat A signal and mark Az and El on mast.
- 5) Switch to Satellite B, maximize Satellite B signal and mark Az and El on mast.
- 6) Split the difference and set Az and El (Signal levels should be approximately equal.)
- 7) Fine tune tilt / skew and elevation if necessary. (If fine tuning performed, you must repeat the above procedure.)
- 8) A minimum of 80 should be obtained on each satellite to be used.

11 CUSTOMER EDUCATION

The following topics should be explained to every customer

11.1 Remote Control

- Basic operation of the Remote control. Refer to owner's manual for each specific manufacturer
- The installer should program the remote control to work with the customer's TV, VCR and all applicable devices
- Explain the DIRECTV Menus and On Screen Guide
- Familiarize the customer with the remote control functions

11.2 Operating the VCR with DIRECTV

- TV must be on and set to channel 3 or 4 or select A/V inputs
- VCR must be on and set to channel 3 or 4 or select A/V inputs
- Be prepared to refer the customer to their owner's manual if they have any questions regarding use of their own television, VCR, etc.

11.3 Explain How to Record DIRECTV Programming

- The DIRECTV IRD must be on and the channel you wish to record must be selected
- The VCR must be set to record either channel 3 or 4 (depending on 3/4 output switch on DIRECTV) or select A/V inputs
- If customer wants to watch what they are recording, the TV channel should match the VCR recording channel (Channel 3 or 4)
- Recording with audio / video - Connect A/V cables to VCR and select A/V input on VCR. RF cable should always be connected so the customer has these options. This will reduce service calls.

11.4 Explain How to Record Off Air & Cable Programming

- The DIRECTV must be set to TV mode using the SAT / TV button. Powering the IRD off will also default to TV mode
- VCR must be tuned to the off-air / cable channel you wish to record
- If customer wants to watch while recording, the TV and VCR must be tuned to the same channel.

11.5 Stereo Connection

- 1) Explain the normal stereo operation – provide a quick overview for the customer.
- 2) Explain / demonstrate to them which stereo input DIRECTV is connected to (e.g.) AUX / CD / etc.
- 3) Other options - if the stereo is connected to the volume controlled audio out of the TV, DIRECTV, off air and VCR signals will pass to the stereo and be controlled by the TV.
- 4) Explain any other reconfigured home electronics components you may have interfaced into the system (e.g., laser disk player etc.).

11.6 Menus – Refer to Owner's Manual for Each Specific IRD

- Menu preferences – Allows customer to change style of displays
- Purchase History and Status – Enables customer to monitor PPV activity and phone status
- Rating and Channel Lockout – Controls the rating of programs allowed to be viewed
- Explain rating codes – G, PG, PG-13, R, NR-MATURE & NC-17
- Favorite Channel Lists – Enables quick access to channels most often watched
- Program Times - Programs are similar to a VCR and should be explained along with the VCR. Daylight savings time changes are automatically set
- Messages – DIRECTV notification of sun outages or upcoming events
- Receiver status – Explain in detail so the customer can assist with future trouble-shooting
- Signal Quality – Explain how customer would use this information for trouble-shooting with Technical Support personnel
- Set or Change Password – This menu item needs to be discussed in detail to ensure proper instruction of previous menu items
- Explain that the password is blank on new or reset units. Once set, it can only be reset by the customer once their password has been entered. Refer to manual for password reset instructions.
- The customer should know to call DIRECTV if they have a problem with the password.

11.7 Additional Customer Information

1) Sun Outages.

Occur in spring and fall (March & October) due to the position of the sun in relation to the satellite. (The sun passes directly behind and in line with the satellite, interfering with the incoming signal for a few minutes a day during a two (2)-week period – this happens with all satellites.)

2) Rain Fade / Snow & Ice in ODU.

Occurs during periods of inclement weather – remember that it does not have to be raining, as moisture in clouds may have the same effect. Explain that snow or ice in the ODU can cause loss of picture. This is most evident with “searching for satellite” message during or after inclement weather. During winter months, removing snow from ODU may clear this problem.

12 MULTI-SWITCHES

12.1 Purpose

Multi-switches can be used when the required number of outlets exceeds the available number of IRD inputs from the ODU. A Multi-switch is needed for three (3) or more IRD inputs when using an 18” ODU and 5 or more inputs when using a Multi-Sat ODU. A second 4-way Multi-switch or an 8-way is required for 5 or more IRD inputs.

12.2 Types of Multi-Switches

It is important to determine the correct switch for your application.

Deciding factors:

- Number of IRD inputs required
- Cable length and amplification
- Multi-switch may require AC power
- Integration of local channel source

Several companies manufacture multi-switches ranging from two (2) to 32 outlets (depending on configuration), both with and without antenna input ports for off- air integration. Always use DIRECTV approved products.

➤ **Note:** *A multi-switch can not be used with a Single output LNB.*

12.3 Multi-Switch Functions

The multi-switch controls the selection of left and right hand polarized inputs from the LNB by sensing voltage from the IRD. Thirteen (13) VDC causes the multi-switch to switch to a right hand polarized signal. Eighteen (18) VDC causes the multi-switch to switch to a left-hand polarized signal

In multi-sat applications, the multi-switch also selects the LNB. A 22 KHz tone generated from the IRD triggers the LNB selection.

All multi-switches pass power to the LNB. Some have external power supplies.

When diplexing / combining the off-air / cable signal with DIRECTV another separate diplexer will be needed. This is required to separate the off-air / cable signal from the DIRECTV signal.

- All powered Multi-switches polarity lock the LNBs
- The LNB is always locked in the 13V (right hand polarity) or 18V (left hand polarity)

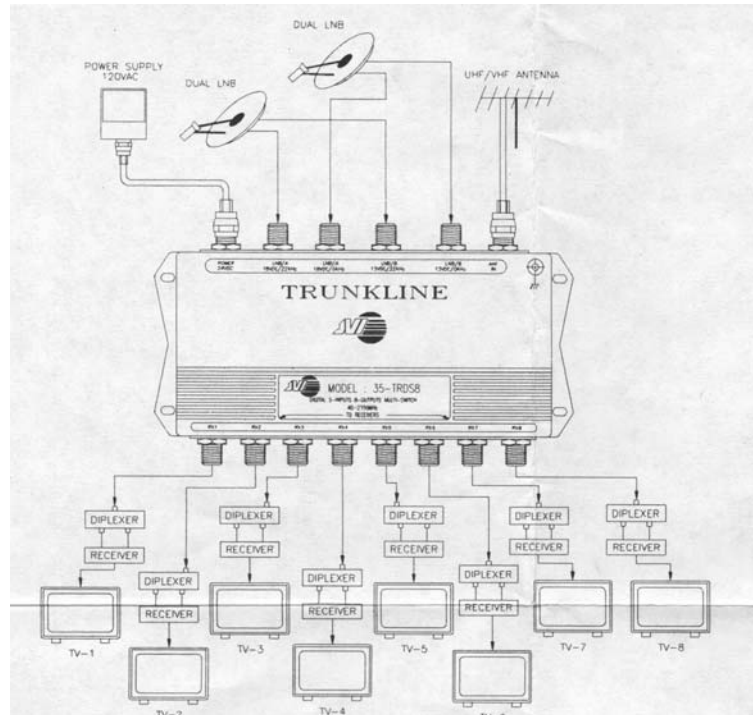

➤ **Note:** IRD powered Multi-switches can sometimes cause micro blocking or momentary loss of picture. This may occur when all IRDs are tuned to a right hand polarity channel (13V) and then one IRD is changed to a left hand polarity channel. This can be difficult to trouble-shoot.

13 INSTALLATION TIPS / Common Installation Problems

13.1 Premature Rain Fade

This problem may be caused by the following:

- ODU not properly peaked
- Long drop with no line amp
- Bad piece of cable or non approved cable
- Corroded F connectors or water in ground block
- Several outlets with high insertion loss through splitters. (Signal quality may be good under blue skies)
- Electrical impulse noise from arcing insulator on High Voltage power lines
- Leaves of a tree drooping down when wet
- Obstruction in line of sight
- Water or insects in the feed horn / LNB
- ODU under eave of home where water runs off roof on ODU

13.2 Useful Equipment for Trouble-shooting:

- Satellite signal strength meter
- Digital VOM
- Spare IRD (any model)
- Telephone test set
- Telephone polarity tester
- Extra phone cord. (10 to 25 feet)
- 100' RG-6 test cable (with connectors)
- Power strip

13.3 Locate IRD's Main Menu and Perform "Systems Test"

- 1) Assess the situation by looking at overall configuration of installation. Note the number of outlets, length of drop, clear line of sight, etc.
- 2) Determine scope of problem.
- 3) Check signal quality to verify that it is greater than 80.
- 4) If signal quality is lower than expected, visually inspect the condition of the LNB.
- 5) Check ODU alignment, re-peak ODU, if necessary.
- 6) Run a temporary cable to the LNB to see if this corrects the problem. If this does correct the problem, move the temporary connection back to the ground block to further isolate the problem. This will allow you to determine which section of the cable may be bad.
- 7) If you suspect the LNB is bad, replace with a known good unit.

13.4 Signal Strength

Remember the key items:

- Every device has an insertion loss
- Signal loss occurs at a rate of approximately 8.5 dBm to every 100 feet of series 6 cable @ 1450 MHz
- Larger diameter cable has less attenuation
- Optimum signal required at the IRD is between -25 and -65 dBm
- Typically, an 18" ODU has a -40 dBm output at the LNB
- Some other helpful hints:
 - Find a distribution point to amplify and distribute signal
 - Install an amplifier / power inserter to power the LNB prior to installing your splitters
 - Splitters should all be Diode protected and dual power passing

13.5 Additional Trouble-shooting Tips

- 1) Check for wireless phone jacks that may be plugged into the same electrical outlets with fluorescent lighting, halogen lamps or other devices that may cause surges in power. Never use wireless phone jacks with advanced products.
- 2) Look for overloaded power strips.
- 3) Check for loose telephone jacks with exposed or faulty wiring.
- 4) Look for possible overheated IRD (may be located in enclosed cabinet with other electronic equipment).
- 5) Check IRD cable connection.

14 TROUBLE-SHOOTING STEPS

- For technical assistance contact the ISS Department at (800) 778-3431. ISS hours are: 7 a.m. - 6 p.m. Mountain time, Monday through Friday.
- Or call your supervisor

- For Retail assistance contact the Retail Department.
- For Customer Service assistance contact the Customer Service Department.

Soft Boot – On most receivers, a Soft Boot is performed by simultaneously depressing the Down Arrow and the Power Button for twenty to thirty seconds. Release the buttons and the receiver will begin set-up. Cancel out of the set-up and check to see if the problem has been resolved.

Hard Boot – Unplug receiver and let sit for 10 minutes. Plug back in and power up. Check to see if problem is corrected.

15 RISK MANAGEMENT

15.1 Property Damage

Every technician is responsible to take appropriate precautions to avoid damage to a customer's property or belongings. In most cases damage and accidents happen when we:

- Lose concentration and skip necessary steps
- Get frustrated with a problem
- Lack of knowledge regarding general construction or proper installation techniques

If damage occurs, immediately notify your supervisor and have a note entered in the account. The customer must always be informed. A minor problem can escalate if not addressed immediately.

Immediate response to customer's claims of damage is required. Potentially harmful situations shall be resolved and repaired with the highest priority.

If the response time of the service provider is not satisfactory or if the situation warrants, the customer may have the problem repaired and the cost of the repair may be deducted from the invoice payment.

15.2 Irate Customers

- At times, irate customers need to release their frustrations, especially when they feel they have been mistreated or their problems ignored. Listening to and addressing their frustration immediately can minimize problems and demonstrate to our customer that we value their business.
- Never argue with a customer! Under no circumstances should a technician continue to work in a situation where physical threats have been made. The technician should leave the job site and contact their supervisor.

15.3 Customer Not Home

When the technician arrives and a customer is not home, review the following items:

- Am I early? Call the customer or have your dispatcher call them
- Review paperwork for accuracy
- Look around to see if customer is outdoors

➤ **Note:** *Under no circumstances should a private dwelling or apartment be entered without the customer, a representative of the customer or the homeowner being present.*

- If the customer is not home, leave a door hanger and contact your office and supervisor immediately. The dispatcher should note the account with a description of the home and time.
- The work order will be rescheduled following DIRECTV procedures

15.4 Late For Appointment ~ Greater than two (2) hours past the START of a window

If you are going to be late for an appointment, always call the customer and notify your office. Dispatch should note the account.

15.5 Technician Responsibility

The last person at a home is responsible for all compliance with DIRECTV standards. This includes but is not limited to NEC grounding and workmanship.

15.6 Clean Up After Installation ~ Small things make a big difference

The customer's house, yard and any work area shall be left CLEAN of any installation debris, including empty boxes, tie wraps, drilling dust, dirt, etc. Vacuum or sweep up any debris created by your installation.

➤ **ALWAYS SHOW PRIDE IN YOUR WORK**

➤ **SHOW RESPECT FOR THE CUSTOMER'S TIME AND HOME**

16 APPENDIX A – STANDARD INSTALLATION STATEMENT OF WORK

The Basic DIRECTV residential installation includes the following:

1. As a minimum, each customer must receive two (2) pre-calls from the Installation Company prior to any work being performed. Contact the customer:
 - Two (2) to three (3) days in advance of their scheduled installation to confirm both the appointment window and work to be performed
 - Installer or dispatcher will phone the customer on the day of the scheduled appointment to confirm when they will arrive to begin the job. In the event that the agreed upon timeframe is in jeopardy, the customer must be contacted and notified of any changes.
 - It is recommended, but not required, to contact the customer within two (2) weeks post installation to confirm customer satisfaction
2. Arrival at customer's residence within the designated window of time.
3. Completion of a site survey and planning the installation with the customer (Cable routing, antenna location, connection of devices). Refer to the DIRECTV Installation Manual - pages 3-1 to 3-3.
4. Verify services ordered and work to be performed with customer. Any non-standard / custom work with incremental costs associated must be communicated and agreed to in writing prior to commencement of installation.
5. Routing and properly attaching approved RG-6 cable through external and internal walls as needed. Routing of cable through attics and / or crawlspaces is considered standard. Refer to the DIRECTV Installation Manual - pages 4-3, 6-1 to 6-2.
6. Use of DIRECTV approved drop materials is required.
7. Grounding to meet Local / NEC requirements. Refer to the DIRECTV Installation Manual - pages 5-1 to 5-4.
8. Properly mounting to customer's home, aligning and peaking satellite antenna for maximum signal strength. Standard mounting includes, but is not limited to the roof, eave, outside wall, balcony, deck and chimney. Refer to the DIRECTV Installation Manual - pages 4-1 to 4-3, 10-1 to 10-3.
9. In any market where local channels are delivered from the 110 or 119 orbital slots or on HD installs or upgrades, a Triple Sat ODU is required on all installations.
10. Dual cable run is recommended from the ODU to the ground block on all installs.
11. Dual cable must be run to all DIRECTV DVRs.
12. Installation of one or more DIRECTV System IRDs as indicated on the customer's work order.
13. All IRDs must be connected to a land based telephone line. Refer to the DIRECTV Installation Manual - pages 7-1 to 7-2.
14. Connection of existing off-air antenna or active cable drop (enabling TV to function as it had prior to DIRECTV installation).
15. Connection of existing co-located devices (VCR, functioning surround sound, DVD, video games, etc.) and programming the DIRECTV Universal Remote Control to operate all applicable devices.
16. Completion of a system test verifying signal strength, access card match and telephone connectivity. Refer to the DIRECTV Installation manual Page 13-1.
17. Activation of DIRECTV service with the customer on the phone.
18. Cleaning up any mess made during installation and removing debris from the customer's residence. This includes removal of empty equipment boxes at customer's request.
19. Customer education on system operation and features (min. 20 minutes). Refer to the DIRECTV Installation Manual - pages 11-1 to 11-2.
20. Completion of all applicable forms and obtaining customer's signature certifying the job was completed to their satisfaction.

21. Leaving installation company name and toll free telephone number if applicable with the customer enabling them to contact the Installation Company directly if there are any problems with the installation.
22. If, after arriving at a job the installation cannot be completed and is cancelled, the installer must explain to the customer in detail why they were not able to complete the job.

June 2003

The information contained on this page is confidential, proprietary DIRECTV business information and is intended for authorized users only. Unauthorized use, disclosure or copying of this information is strictly prohibited and may be unlawful.

17 APPENDIX B – CUSTOM WORK CHARGES

DIRECTV RECOMMENDED RATES FOR REQUESTED SERVICES BEYOND WHAT IS PROVIDED IN A STANDARD PROFESSIONAL INSTALLATION

The following list contains DIRECTV's recommended rates for additional services applicable nationwide. These rates were established after reviewing all current HSP charges for such services, taking into account retail rates so that these rates are reasonably competitive. These rates shall be distributed to all DIRECTV Entertainment Consultants nationally in order to help educate DIRECTV customers as to what the approximate rates should be for certain services not included in a standard professional installation. **ADDITIONAL CHARGES TO BE PAID TO THE INSTALLATION COMPANY UPON COMPLETION OF INSTALLATION:**

Work	Not to Exceed
Wall Fish	\$60.00 per
Pole Mount Removal Dig	\$65.00
Pole Mount Removal Cut	\$20.00
Pole Mount / per Customer's Request	\$75.00
Sidewalk Bore	\$35.00
Mirror Outlet	\$45.00
Additional Outlets without Receivers	\$45.00
Additional Outlets with Receivers	\$45.00
Separate Trip Additional Outlets	\$85.00
Non-Penetrating / Sled Mount	\$65.00
Balcony Mount / Brackets	\$30.00
Flat Cable Jumper	\$5.00
Bury Cable / Outlet	\$30.00
Line Amps	\$15.00
Diplexers (2)	\$15.00
Wireless Phone Jack	\$75.00
Relocate Dish (Customer Request)	\$97.50

June 2003

The information contained on this page is confidential, proprietary DIRECTV business information and is for authorized users only. Unauthorized use, disclosure or copying of this information is strictly prohibited and may be unlawful.



All technicians must be SBCA certified



To obtain information on the Satellite Broadcasting and Communications Association

- (800) 541-5981
- www.SBCA.com

